

Jacob Veatch

Advisors: Dr. Peter Orazem, Gavin Jerome

An Analysis of Comedy College: A look into the data of students and their comedy.

Objectives

- Watch and collect data from recorded Comedy College standups
- Visualize data in an analyzable format
- Determine correlations in data to figure out what makes comedians funny

Determining a Data Model

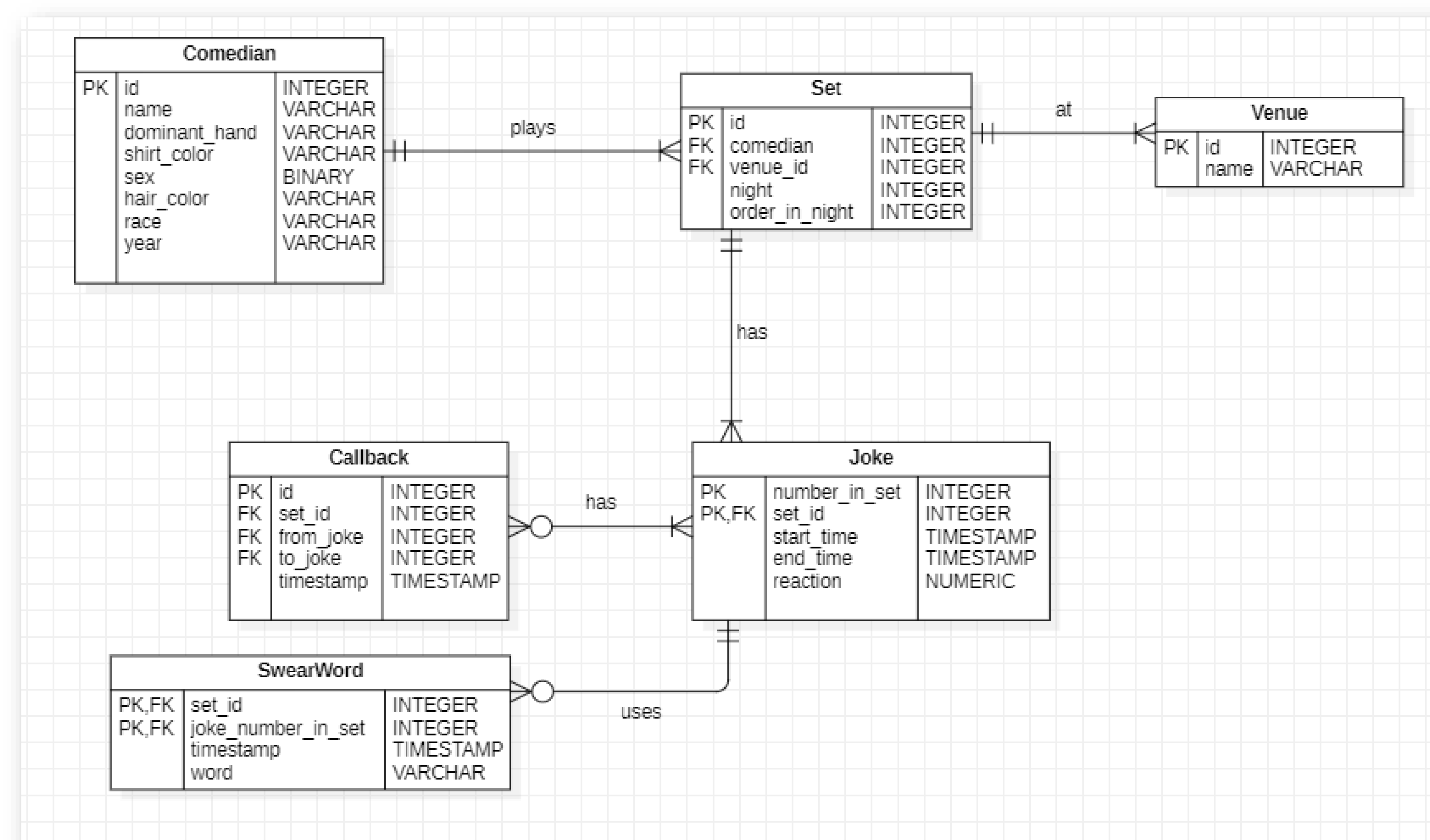

Collecting Data

- 4 Semesters
- 48 Comedians
- 399 Minutes
- 690 Jokes
- 106 Swear Words
- 26 Callbacks

Crowd Response

Measure of the crowd reacting to a joke from a scale 1-10 (1 being horrible, 10 being the best).

Visualizing Data

- R Programming Language
- R Markdown
- Tidyverse (ggplot2 for graphing)

Results

